

IMPROVE PRODUCTIVITY AND GET MORE ONTO THE PALLET WITH THE FLEXIBLE SOCO SYSTEM PALLET LOADER



SOCO
SYSTEM
www.socosystem.com

PACKING SOLUTIONS FOR CURRENT AND FUTURE NEEDS

Better freight economy, an end to strenuous activities, improved productivity, fewer days lost through sickness. These are some of the benefits of investing in a SOCO SYSTEM pallet loader.

More on the pallet

All cases, including heavy and bulky ones, can easily be stacked to heights of 2500 mm in order to fully utilise the capacity of lorries and containers.

Safe to operate, simple and versatile

The machine requires minimal maintenance and is easy to service.

The machine is available with either left or right-hand operation.

With or without an operator

SOCO SYSTEM pallet loaders can be used as an efficient semi-automatic aid for the operator, or integrated into a fully automated palletising system (see back page).



When the operator stands on the safety mat, the machine is deactivated.



The roller table facilitates transfer to the stripper plate.



On the stripper plate, the operator forms the desired pattern.



The simple press of a button transfers the case layer to the pallet.

Simple and safe operation

The program is simple and self-explanatory, and is operated using a finger touch panel. When the stripper plate is filled, the operator stands on a safety mat that deactivates the machine. The machine is supplied with safety screening.

Stainless steel for wet environments

The pallet loader and the rest of the product range are available in galvanised or stainless steel.

The machine can be ordered in special colours at additional charge.

17 tonnes a day

A typical example of palletising work is an operator who has to lift 10 kg cases. Four cases are to be placed on a pallet every minute. In one hour, 2.4 tonnes will have been lifted, equivalent to 17 tonnes a day. In a week this mounts up to 85 tonnes, which is equivalent to two medium-sized tanks!

Lifting places a strain on the body's joints, muscles and tendons, especially in the back. Lifting can cause injury either as a result of a heavy, expected or unexpected strain, or as a result of strenuous activity over a prolonged period.

SOCO SYSTEM pallet loaders remove the need for repetitive lifting of heavy loads, resulting in productivity improvements.

Phone us!

We can advise you on your existing and future packing requirements and provide you with a specific proposal and quotation.

GENERAL SPECIFICATIONS

The pallet loader is available in three standard widths:

PL-1208 is designed for Euro pallets. Max. pallet length 1200 mm and max. pallet width 800 mm.

PL-1210 is designed for pallets up to a max. pallet length of 1200 mm and a max. pallet width of 1000 mm.

PL-1212 is designed for pallets up to 1200 x 1200 mm. Max. pallet length 1200 mm and max. pallet width 1200 mm.

Three tower heights:

2500 mm, 3000 mm and 3500 mm.

This allows pallets to be loaded to heights of 2500 mm depending on the height of the case.

Case height:

Up to 750 mm.

Weight per layer:

Up to 250 kg.

Capacity:

Up to 3 layers per minute.



The safety switch deactivates the machine on contact.

Pallet guides ensure correct placement of the pallet.

Ready for the future

1. Manually operated version. The pallet loader in the examples is gradually extended with various function modules, resulting in an increasing degree of automation and functionality.

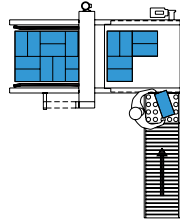

1

2. A pallet loader combined with a pusher for transferring cases to the stripper plate. Column-stack loads are palletised automatically. Interlocking loads require manual turning of the cases before they reach the pusher.

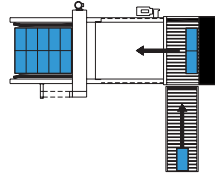

2

3. By adding a case turner, the system can automatically form individual interlocking pallet layers. This makes the pallet load more stable.

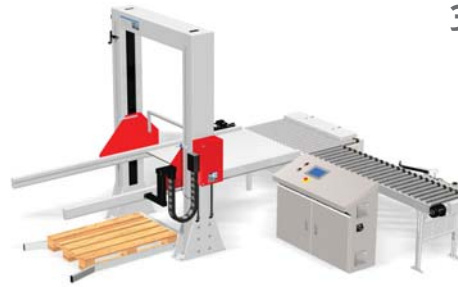
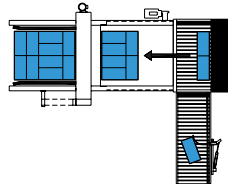

3

4. Complete fully automatic palletising system with pallet magazine and pallet roller conveyors.

All modules are part of the SOCO SYSTEM product range.

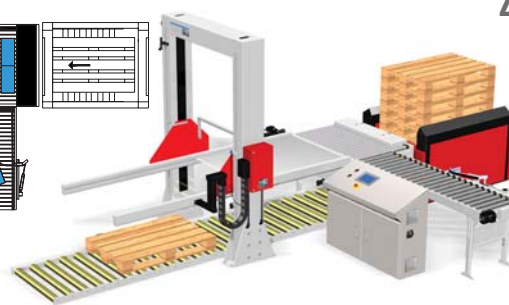
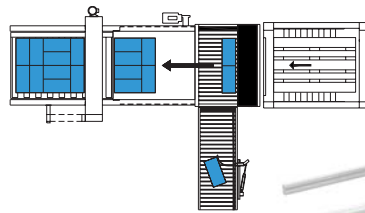

4

Your SOCO SYSTEM dealer:

Head office:

SOCO SYSTEM A/S
 Helgeshøj Allé 16D
 DK-2630 Taastrup
 Denmark
 Tel +45 43 52 55 66
 Fax +45 43 52 81 16
 info@socosystem.com
 www.socosystem.com



Geberit AG,
Switzerland



Sig. Ágústsson,
Iceland



Laru,
Germany



Toms,
Denmark

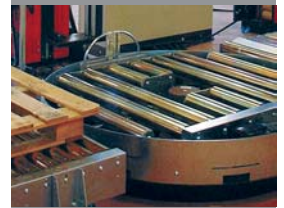

Rioja,
Spain



Bouché Père & Fils,
France



United Milk,
United Kingdom



Altmark Käserei,
Germany