

# Semi Automatic Carton Sealer with Automatic Top and Bottom Closure

**T-10**  
For Uniform  
Cartons

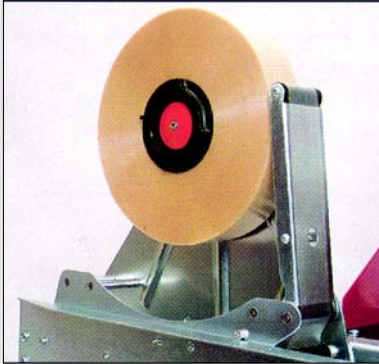

High quality tape dispensers



Easy and quick height adjustment

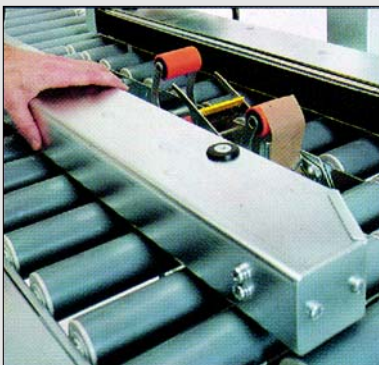

Efficient side drives

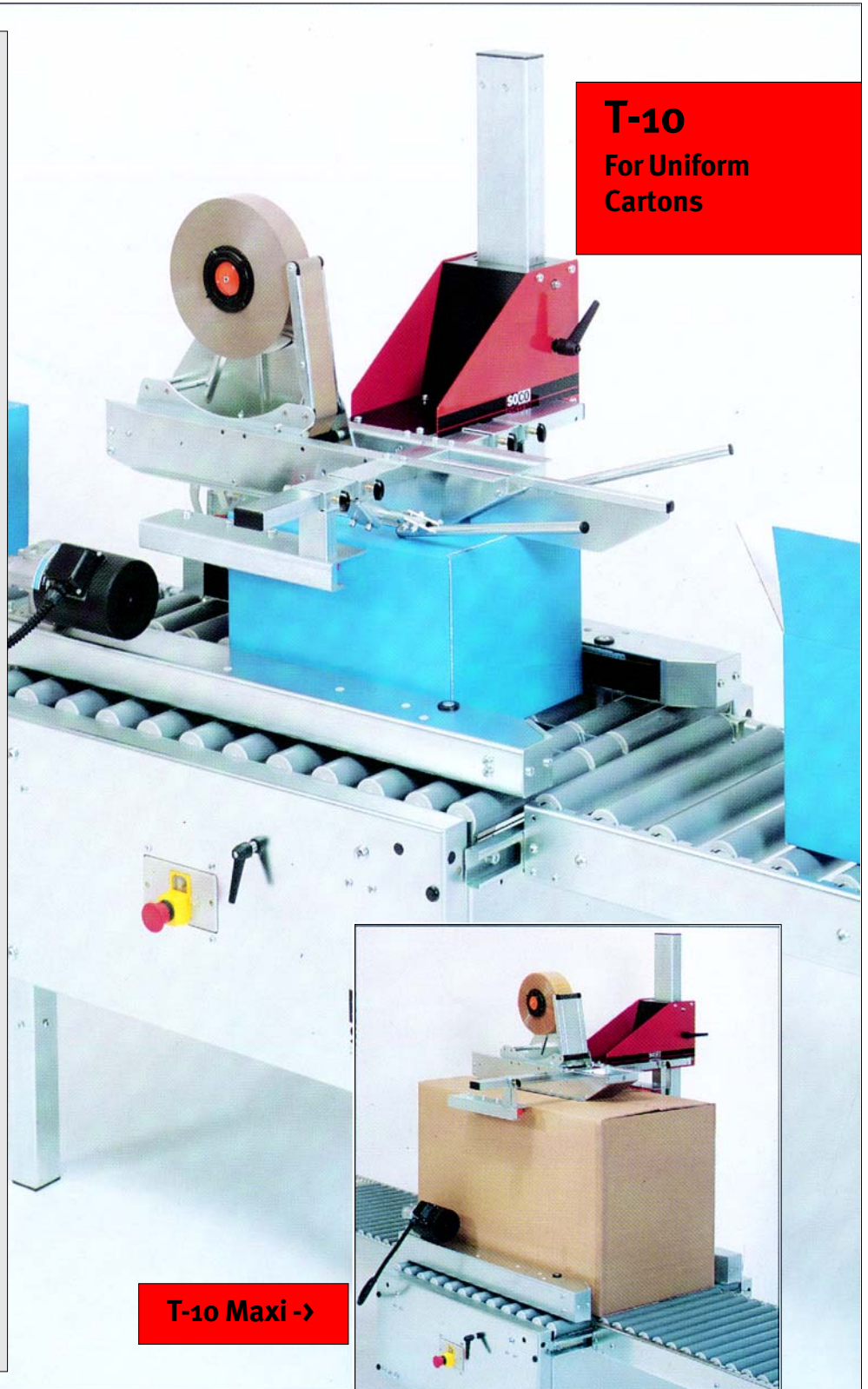

T-10 Maxi ->

**SOCO**  
**SYSTEM**

# Purpose-built for “round the clock” applications. Simultaneous top and bottom sealing of uniform carton sizes in batches. Simple and quick adjustment for carton size.

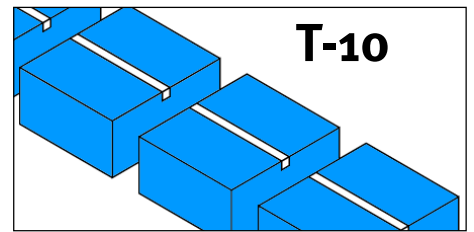

## Basic models

The T-10 is available in two standard constructions, the T-10 and the T-10 Maxi. Both models are available with extra high pillars (see table).

The T-10 is available with an electro-zinc or an 18/8 stainless steel finish. In the stainless steel version, all external parts excl. gears, motors and aluminium parts are made of 18/8 stainless steel. The machine is easy to clean and resistant to damp and moisture.

## T-10 Maxi

A wide version of the standard T-10. Suitable in industries where large cartons are handled. In its standard version, the T-10 Maxi is fitted with 100 mm dispenser with 70 mm tape overlap.

## High Quality Tape Dispensers

The thumbscrew of the tape roller hub makes tape replacement easy and, at the same time, ensures tape roller stability during the sealing process.

Three dispenser types can be used for the T-10 series:

- 30 mm dispenser for tape ranging in width from 25-30 mm. The tape overlap is 50 mm
- 50 mm dispenser for tape ranging in width from 38-50 mm. The tape overlap is either 50 mm or 70 mm.
- 75 mm dispenser for tape ranging in width from 50-75 mm. The tape overlap is 70 mm.

All of SOCO SYSTEM's dispensers are fitted with an adjustable hub brake, adjustable tape roller hub, double roller units, knife guards etc.

All the dispensers can be fitted with a monitoring system to supervise the sealing process.

## Comprehensive Programme

The T-10 series forms only a small part of a comprehensive selection of carton sealers and conveyor systems. Ask for our main catalogue.

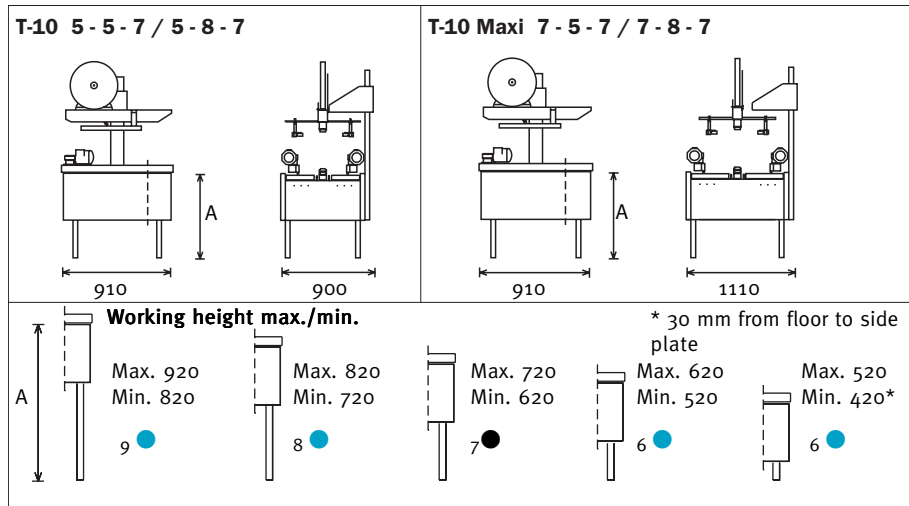

Model	Carton Dimensions**			Tape overlap	Dispenser width			Capacity**	Side drives				Shipping carton dimensions			Weight KG.	
	Length	Width	Height		25-30	38-50	50-75		50	80	50	80	Length	Width	Height		
<b>T-10 5-5-7</b>	Max. ∞ Min. 90	515	505 80/120*	●	●	●	●	●	●	●	●	●	●	1310	810	900	165
<b>T-10 5-8-7</b>	Max. ∞ Min. 90	515	815 80/120*	●	●	●	●	●	●	●	●	●	●	1310	810	900	165
<b>T-10 Maxi 7-5-7</b>	Max. ∞ Min. 140	725	505 110/150*	●	●	●	●	●	●	●	●	●	●	1310	1020	900	170
<b>T-10 Maxi 7-8-7</b>	Max. ∞ Min. 140	725	815 110/150*	●	●	●	●	●	●	●	●	●	●	1310	1020	900	170
<b>General</b>	Electrical equipment: 3x230/400 V 50-60 Hz or 3x415/460 V 50-60 Hz Connected load 0,3 Kw Other specifications available on demand.			Taperoller dimensions: 													

- Standard
- Optional

All measurements are in mm.  
Right to alter specifications reserved.

\* Without and with side pressure rollers.

\*\* Depending on the quality, construction and size of the box.

## SOCO SYSTEM A/S

Helgeshøj Allé 16 D . DK-2630 Taastrup  
Tel. +45 43 52 55 66 . Fax +45 43 52 81 16  
info@socosystem.com  
www.socosystem.com